



Commander 3 Axis Gantry Scanner

Applications:

Sheet goods, large parts,
surface roughness, gasket scanning.

Specs:

MODEL # CMDL2018Z

X Travel	455mm (18 inches)
Y Travel	305mm (12 inches)
Machine Weight	50kg (110 lbs)
Electrical Requirements	120V
Air/Water Required	None
Sample Size Max	455x305mm (18 x 12 inches)
Sample Weight Max	454kg (1000lbs)
Resolution X	Depends on ballscrew chosen (typ. 1.25µm)
Resolution Y	Depends on ballscrew chosen (typ. 1.25µm)
Resolution Z	Varies on sensor (typ. +/-0.500 µm)

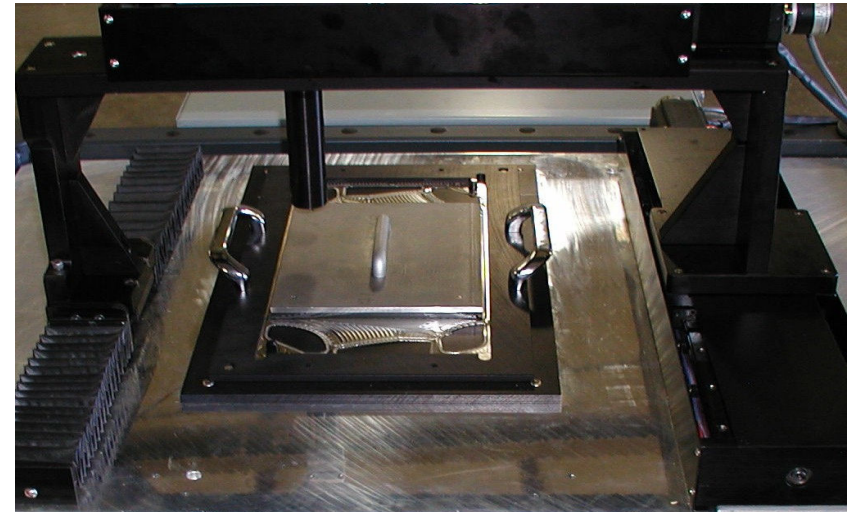

Options:

Ultra Precision Ballscrew	(1, 2, 5, & 10 mm/rev)
X Travel	200 – 1524mm (8 – 60 inches)
Y Travel	200 – 1524mm (8 – 60 inches)
Air Table Option Available	
Multiple Sensor Configurations Available	
Standard Sensor	2mm range @ 1µm resolution
CLA options	0.14mm-10mm @.01 µm resolution
Line Laser options	Standard Line, High Speed Line, & Long Range Line
Alternative Power Options Available	(110/220/230V 50/60 HZ)

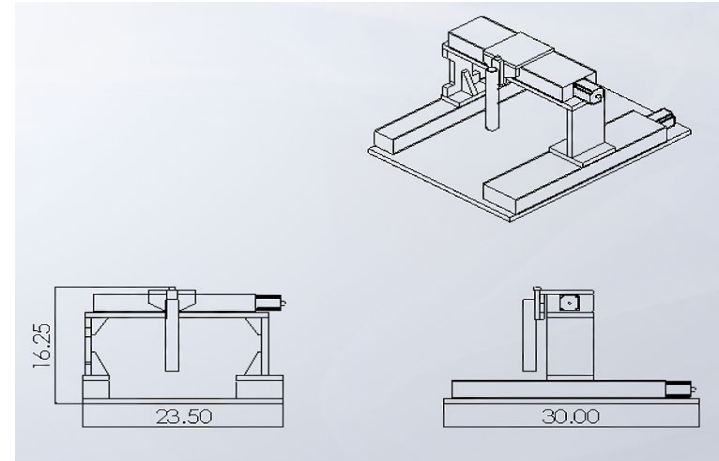

Warranty : 1Yr parts/labor. User pays shipping to service center. Return shipping included.